

NONLINEAR DYNAMIC CHARACTERISTICS AND RESONANT ACTUATION OF BI-STABLE COMPOSITE LAMINATES

YUTING LIU¹, JIAYING ZHANG², QISHAO WANG³ AND QINGYUN WANG⁴

¹School of Aeronautic Science and Engineering, Beihang University
Beijing 100191, China
1342921164@qq.com

²School of Aeronautic Science and Engineering, Beihang University
Beijing 100191, China
jiaying.zhang@buaa.edu.cn

³School of Aeronautic Science and Engineering, Beihang University
Beijing 100191, China
wangqishao@buaa.edu.cn

⁴School of Aeronautic Science and Engineering, Beihang University
Beijing 100191, China
nmqingyun@163.com

Key words: Morphing Structure, Bi-stable Composite Laminate, Non-linear Dynamics, Resonant actuation, Snap-through

Abstract. *In the fields of morphing aircraft design, flow control and broadband energy harvesting, the dynamic characteristics of the multi-stable structure provide an idea for realizing the dynamic deformation of configurations. Its unique nonlinear characteristics and local strong stability provide an important theoretical basis and application value for the investigation of morphing structures. Taking asymmetric bi-stable composite laminates as the research object, this paper analyzes the effects of boundary conditions on the stable configurations and utilizes finite element simulation software ABAQUS to research the nonlinear dynamic characteristics of each configuration and its dynamic response under different excitation levels. By comparing two boundary conditions of cantilever and clamped at the center, the dynamic snap-through phenomena of bistable laminated panels are investigated, and the morphing strategies targeting modal frequencies need to be optimized.*

1 INTRODUCTION

The bi-stable composite laminates with asymmetric lamination have two statically stable configurations^[1]. The stable configuration means that the laminates can keep the natural stability without external energy, and each stable configuration has a certain loading capacity. We define the physically sudden transition between the stable configuration as the snap-through. Due to the non-linear vibration of the laminates, the large deflection distortion between different steady states can be realized by small energy input. Bi-stable composites

laminates are widely applied in the morphing aircraft of aerospace engineering, broadband energy harvesting, flow control and nonlinear vibration isolation^[2-4].

In 1981, Hyer first discovered the bistability of unsymmetrically laminated laminates during the curing process^[1]. The experimental results show that the laminates cure into right cylindrical rather than saddle-shaped, as predicted by classical laminates theory. The shape of laminates is shown in Fig.1. This property appears as a result of residual thermal stresses induced during the curing process due to an unsymmetric stacking sequence. The bi-stable mechanism is caused by warping of the structure, which results in an opposite sign curvature for each stable state^[5]. Bi-stable composites have been previously actuated for configuration control using shape memory alloy (SMA) wires and Macro Fiber Composites (MFC) under a quasi-static loading^[6-8]. The former showed good actuation authority, however, it is difficult to establish a theoretical model between SMA and laminates^[9]. The MFC actuation system was easily glued on the bi-stable structures, but the stiffness of the MFC patch itself has a significant influence on the curvature of the stable configurations. Furthermore, very high voltages were required to drive the MFC actuator even for very compliant [MFC/0/90/MFC] two-ply plates^[10].

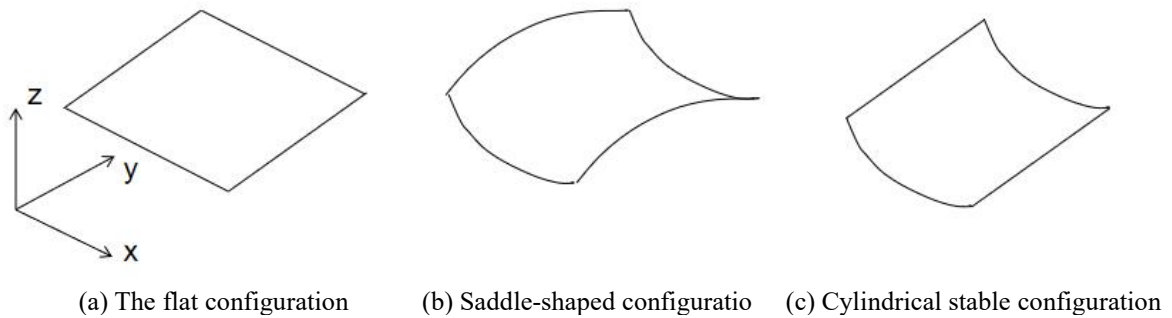

Figure 1: The configurations of Orthogonal laminates

Due to the bi-stability, the asymmetric laminates exhibit complicated dynamic characteristics including sub-harmonic and chaotic oscillations^[11,12]. Many scholars consider this property, therefore proposing dynamic actuation strategies. In 2010, Senba et al. proposed a method of dynamic morphing using the frequency resonance of the bi-stable laminates integrated with the MFC patch^[13]. Applying an alternating voltage to the MFC to trigger the laminates to vibrate, when the amplitude of the laminate augments to a critical value, the laminate could induce the snap-through even though the generated force of the fibers is small. However, in order to induce the snap-through of the bistable laminates, the point mass needs to be added on the laminates, which increased the inertia force for the dynamic morphing. In 2013, with the same morphing strategies, Arrieta et al. designed a dynamic actuation strategy of two-way snap-through using the MFC actuators with a relatively small voltage of 300V^[14]. Zhang et al. exploited the dynamic snap-through and non-linear vibration of bi-stable asymmetric laminated composite square plates under foundation excitation theoretically and experimentally. The time-varying principal curvature is induced for the first time in this type of problem and they obtain two-degree-of-freedom nonlinear ordinary differential governing equations of motion for the bi-stable laminates^[15].

In this article, a dynamic morphing strategy of asymmetric bi-stable composite laminated rectangular plates are presented. Two boundary conditions of cantilever clamping and clamped at the center are analyzed by finite element method. The dynamic response of Exploit. This paper discusses how to optimize the resonant actuation methods to control the transition between stable configurations.

2 THE FINITE ELEMENT MODEL OF THE ASYMMETRIC BI-STABLE COMPOSITE LAMINATES

The asymmetric bi-stable composites laminated plate is made of a carbon fiber reinforced prepreg 5428/CCF300, cured at 200°C and then cooled to room temperature 20°C. Due to the difference in thermal expansion coefficient between vertical direction and parallel direction, a mismatched shrinkage strain is produced, resulting in residual stress. The material parameters of the prepreg are shown in Table 1.

The size of the asymmetric bi-stable composite laminates is 200mm \times 75mm and the sequence of the stacking is [0/0/90/90]. The laminates of the two boundary conditions have the same size and lay-up sequence, and a 40mm length area is fixed. A schematic of the structure is shown in the Fig.1. The thickness of the prepreg is 0.125 mm, which is much smaller than the length and width of the structure. Therefore, the shell element S4R is used in the finite element simulation. Two quasi-static analysis steps are used to predict the stable configuration of the bistable laminates with the nonlinear set “NLGEOM” switch on. In the first distribution step, only one stable configuration can be obtained. In order to obtain both stable configurations, displacement perturbations are needed at four angles. The first natural frequencies of the configuration are obtained by modal analysis, then dynamic analysis is carried out.

Table 1: Material parameters are given for the asymmetric bi-stable composites laminates

Parameter		Unit	Value
Axial tensile modulus	E_1	GPa	145
Transversal tensile modulus	E_2	GPa	9.75
Shear modulus	G_{12}	GPa	5.69
Shear modulus	G_{23}	GPa	5.69
Poisson's ratio	ν_{12}		0.312
Longitudinal thermal expansion coefficient	α_1	°C ⁻¹	4E-7
Transverse thermal expansion coefficient	α_2	°C ⁻¹	2.5E-5
The thickness of layer	t	mm	0.125

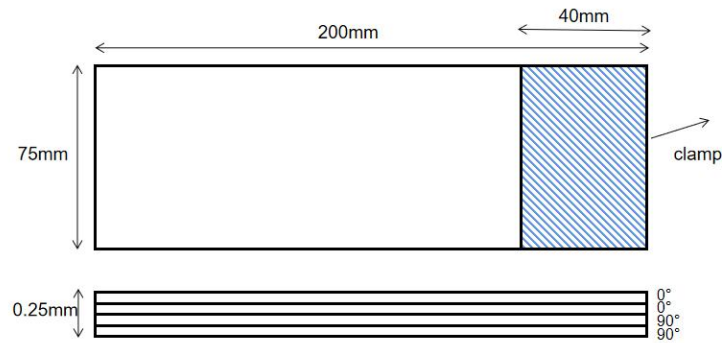

Figure 1: The size and lay-up of the bi-stable composite laminate

2.1 Center-clamped asymmetric bi-stable composite laminate

The two stable configurations of the asymmetric bistable laminates are predicted by the finite element model. The boundary conditions with fixed midpoints are shown in Fig. 2. The two stable configurations are cylindrical in shape and the stress distribution is relatively uniform. Because of the boundary effect, the stress of the cylinder configuration changes at the boundary. This articles define the configuration that the principal curvature direction coincides with the long side of the plate as the stable state A. The principal curvature direction of stable state B coincides with the short side of the plate

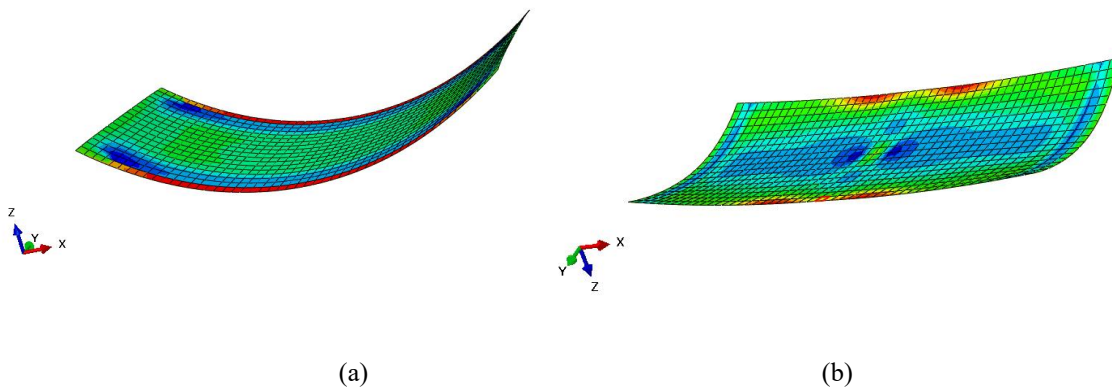

Figure 2: The stable configuration of the bi-stable composite laminate (a)stable state A (b)stable state B

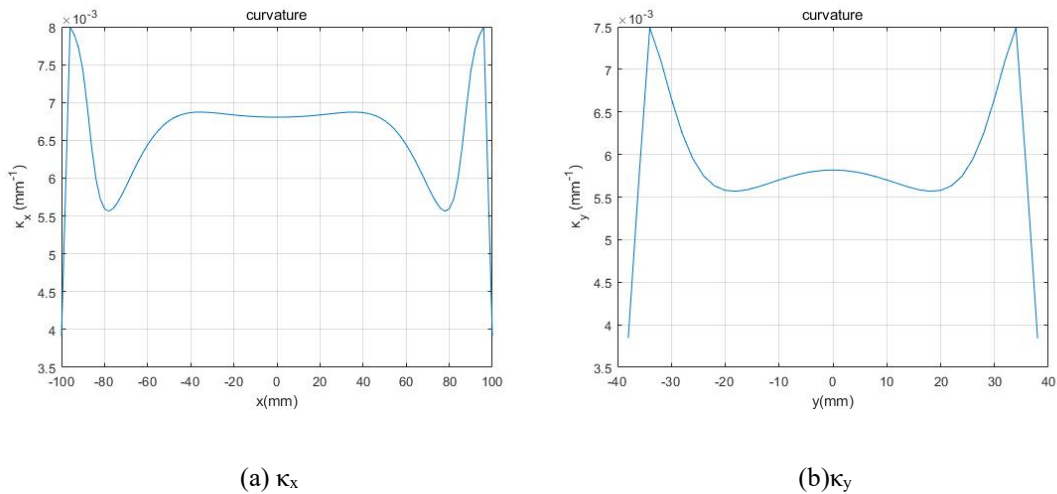

Figure 3: The principle curvature of two stable configurations (a) the principle curvature of stable state A (b) the principle curvature of stable state B

Figure 3 shows the principle curvature of two stable configurations. The bi-stable laminate with orthogonal ply-up has two stable configurations whose principal curvature directions are perpendicular to each other. In the principal curvature direction of stable state A, the longitudinal curvature of the laminate is plotted along the long side. The curvature of the plate is symmetrically distributed in both directions, and the curvature increases from the minimum value of the two free edges to the maximum. There is a large variation at the boundary, and in the intermediate area, the curvature is uniformly distributed. The curvature and area with uniform curvature distribution of the stable State B is smaller than that of the stable State A.

Before the dynamic analysis, the linear natural frequencies and modes of the bistable laminates are analyzed by finite element simulation. Figure 4 shows the first-order modes of the two stable configurations, respectively. It can be seen that the first-order mode of the bistable laminates is the same as the bending mode of the stable configuration of the laminates, which is also the mode to be concerned in this paper. Since the emphasis of this paper is on the dynamic actuation between two stable configurations by stimulating on their first-order natural frequencies, the higher-order modes are not enumerated. The first-order natural frequency of stable state A is 15.694 Hz, and the first-order natural frequency of stable state B is 17.423 Hz.

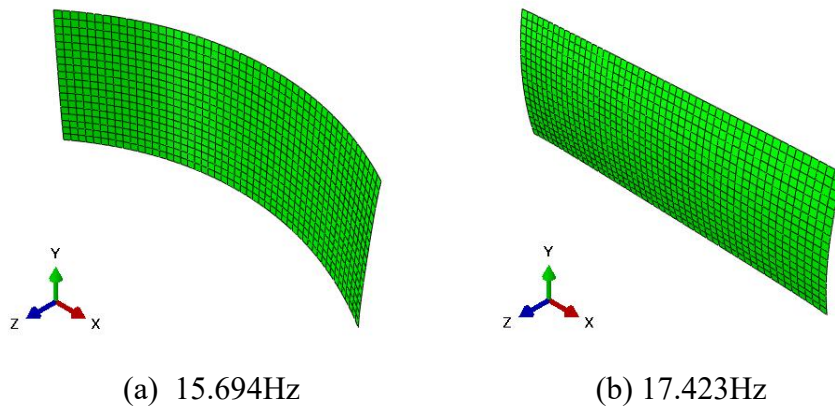
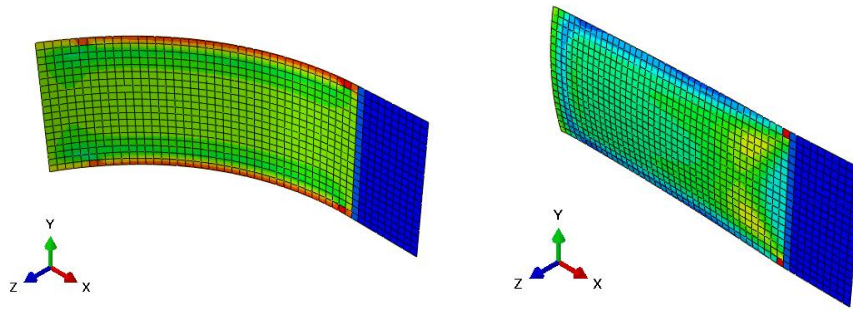

Figure 4: The first-order modal of two stable configurations (a) the first-order modal of stable state A (b) the principle curvature of stable state B

2.2 A Cantilevered asymmetric bi-stable composite laminates

The two stable configurations of the asymmetric bistable laminates predicted by the finite element model under the boundary conditions of cantilever are shown in Fig. 5. The two stable configurations are cylindrical in shape and the stress distribution is relatively uniform. Similarly, we define the configuration that the principal curvature direction coincides with the long side of the plate as the stable state A. The principal curvature direction of stable state B coincides with the short side of the plate. The deformation form of the cantilever fixed laminates is similar to the mid-point fixed laminates. In order to obtain the stable state B under the cantilever boundary condition. Firstly, the right end of the model is fixed and a displacement disturbance is applied during the curing process. Then the displacement disturbance is removed and the stable state B configuration is obtained. This is different from the actual situation of first curing and then fixing the right end. In the experiment, the restraint of the bi-stable laminated plate will slightly affect the configuration of the specimen.

Fig. 6 depicts the longitudinal curvature curve of stable state A and the transverse curvature curve of stable state B. It is observed that the fixed end has a great influence on the curvature of stable state A, but almost no influence on the curvature of stable state B. The longitudinal curvature of stable state A increases rapidly from 0 at the fixed end to the maximum, and the middle area tends to be flat. Afterwards, it increases and then decreases near the free end. Because of the asymmetric constraint, the curvature of stable state A is no longer symmetrical. The transverse curvature of B is consistent with the curvature of fixed bi-stable laminates.



(a)

(b)

Figure 5: The stable configuration of the bi-stable composite laminate (a)stable state A (b)stable state B

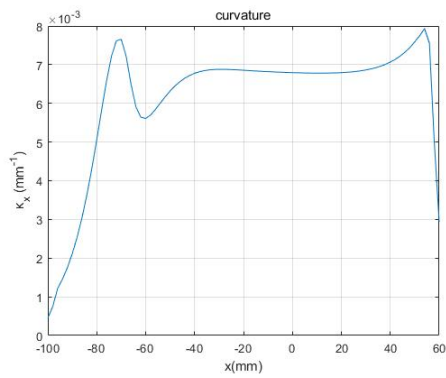

(a) κ_x

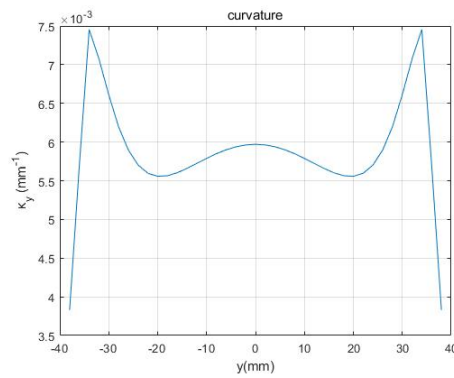

(b) κ_y

Figure 6: The principle curvature of two stable configurations (a)the principle curvature of stable state A (b)the principle curvature of stable state B

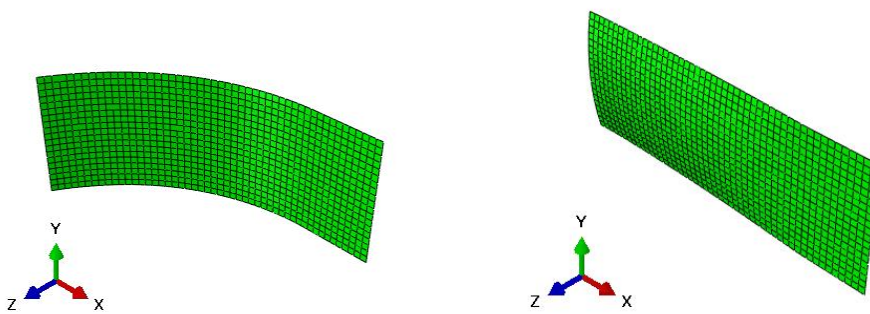

(a) 13.115Hz

(b) 23.329Hz

Figure 7: The first-order modal of two stable configurations (a)the first-order modal of stable state A (b)the principle curvature of stable state B

Fig. 7 shows the first order mode and first-order linear natural frequency of two stable configurations of cantilever bistable laminated plates. The first-order mode is similar to the structure of the stable configuration. In the subsequent dynamic analysis, the first-order linear natural frequency of the configuration is taken as the frequency of external excitation.

3 DYNAMIC ANALYSIS OF THE ASYMMETRIC BI-STABLE COMPOSITE LAMINATES

The main purpose of this paper is to study the dynamic characteristics of bistable composite laminates driven by resonance, which can provide a more efficient actuation. By optimizing actuation strategy, achieve single snap-through and two-way snap-through as freely as required. The frequency of the free vibration of the nonlinear system is no longer a constant but closely related to the amplitude of the external excitation. In this chapter, the effect of amplitude on the dynamic response of structures at first-order linear natural frequencies is explored.

The nonlinear vibration of bistable plates includes periodic vibration, quasi-periodic vibration and chaotic vibration. When the amplitude of excitation is small, the asymmetric bi-stable composite laminated plate makes a small amplitude periodic vibration around the equilibrium configuration. When the amplitude of excitation gradually increases, it makes a small amplitude quasi-periodic vibration near the equilibrium configuration. When the amplitude increases to a certain range, the chaotic motion with large amplitude will occur between equilibrium configurations accompanied by the single snap-through or two-way snap-through. Chaotic vibration generally occurs before snap-through of the bi-stable laminates, and chaos vibration is a favorable condition for snap-through.

3.1 Dynamic analysis of a center-clamped asymmetric bi-stable composite laminate

First of all, the dynamic response is studied when the initial configuration is stable state A. The first order natural frequency 15.694 Hz is selected as external excitation frequency, and the excitation amplitude ranges from 0.1 mm to 15 mm. With five representative reference data sets selected, Fig.8 demonstrates the displacement and the phase portrait of the midpoint of width when the excitation amplitude value from 0.1mm to 15mm.

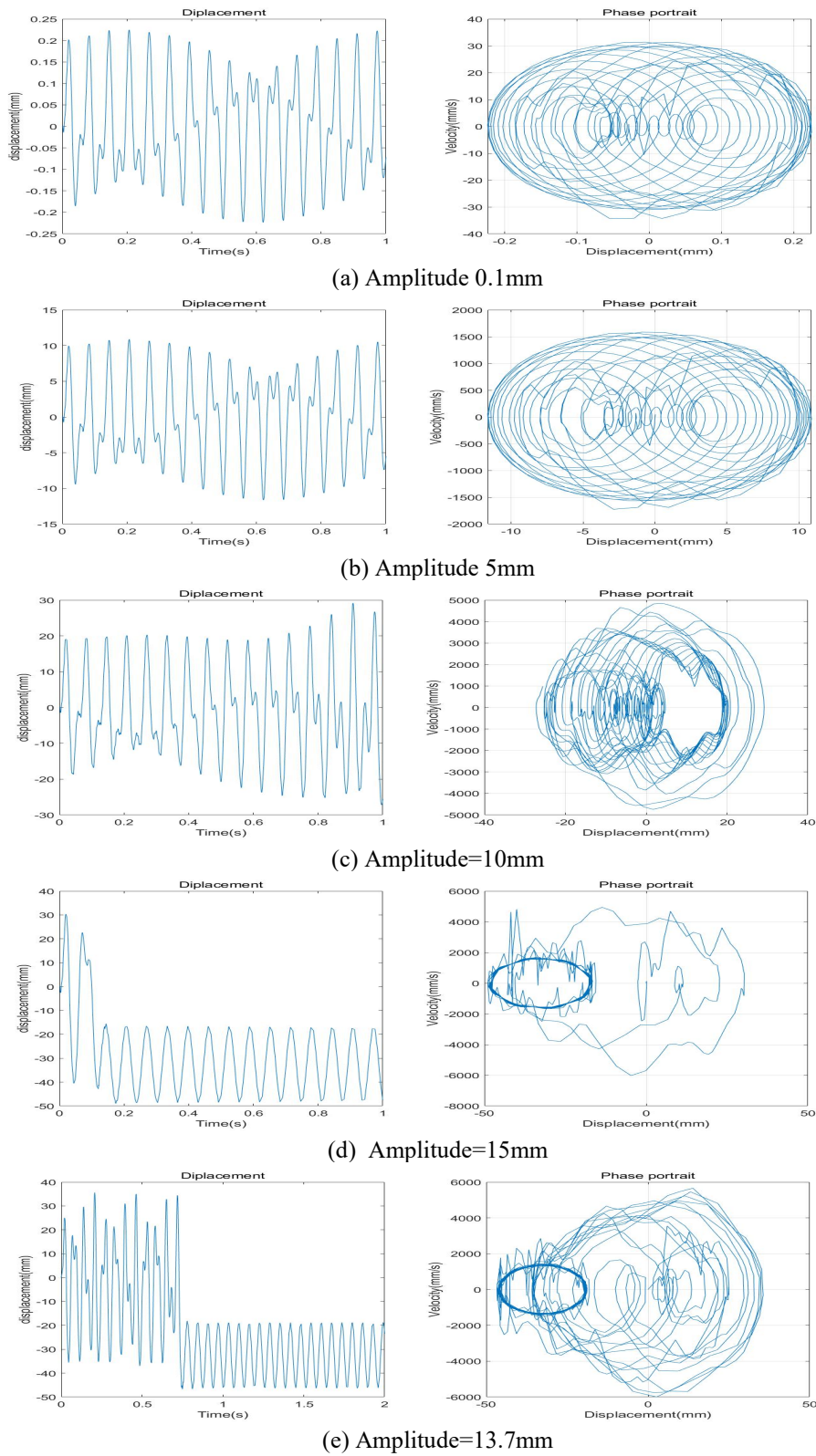

Figure 8: The displacement and the phase portrait of the asymmetric bi-stable composite laminates from stable state A to stable state B

When the amplitude is 0.1 mm, the bistable composite laminates oscillate with a small amplitude near the equilibrium point. When the excitation amplitude is increased to 5 mm, although the bistable composite laminates continue to move around the equilibrium point with a larger amplitude, the bistable laminates still in periodic motion and cannot reached the critical value of jump. At this point, the amplitude of the dynamic response is approximately twice that of the excitation. When the amplitude is further increased to 10mm, the structure response is further enhanced. The phase portrait which begins to show regional differential means a tendency to snap-through. When the amplitude increases to 15 mm, the plate snaps quickly after 0.1 and then vibrates periodically around the stable state B. It can be predicted that when the amplitude increases to a critical value, the structure can make a large amplitude two-way snap-through between the two steady states.

The critical amplitude for snap-through is 13.7 mm, as shown in Fig. 8(e). The chaotic vibration of the system begin to appear after 0.7s, and then the snap-through occurred. The bi-stable laminates induce snap-through during the chaotic vibration, subsequently. the laminate begins to do periodic vibration near the stable state B. When the configuration is deformed, the frequency of external excitation is different from the natural frequency of the current structure. Due to the structure will become stiffen, the amplitude response will be at a lower value. The stiffness of stable state B is obviously higher than that of state A, after which the amplitude of the vibration around stable state B is similar to external excitation amplitude.

The dynamic response of stable state B is explored when the frequency of external excitation is 17.423 Hz and the amplitude increases from 1 mm to 21 mm. Five groups of representative data were selected to draw displacement curves and phase diagrams, as shown in the Fig. 9. Because the stiffness of state B is larger than stable state A but the deformation of State B is smaller, state B is more stable and requires more energy to stimulate snap-through. When the amplitude is smaller than 16 mm, the structure oscillates slightly initially and then vibrates periodically around stable state B. Despite the resonant frequency, the structure does not produce large deflection deformation. The deflection of state B is much smaller than that of State A, and the stiffness is larger. The inertial acceleration at the end of state B is smaller, so the inertial force is not enough to stimulate snap-through. When the driving amplitude is 21mm, the amplitude exceeds the critical value of snap-through, the two-way snap-through between two states can be observed in Fig. 9(e). Two-way snap-through chaotic oscillations occur between the two stable states because the energy provided by the excitation is large enough.

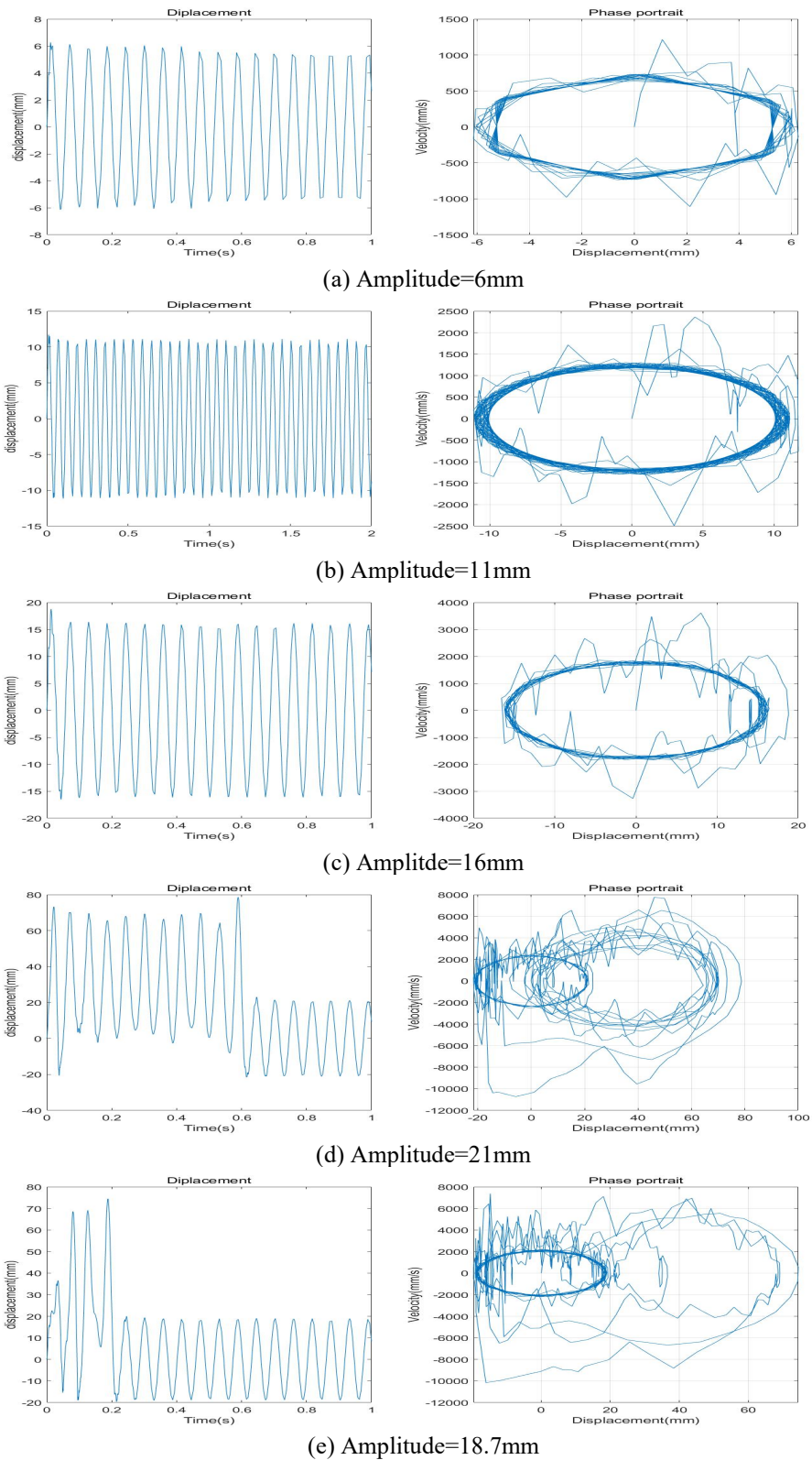

Figure 9 The displacement and the phase portrait of the asymmetric bi-stable composite laminates from stable state B to stable state A

The critical amplitude of the snap-through is 18.7mm, and there is obvious oscillation after the load is applied and when the snap-through occurs. Finally, the periodic vibration occurs near the stable state B, when the amplitude is almost the same as that of the external excitation.

It can be observed from the two sets of data that the nonlinear characteristics of stable state A are stronger than those of stable state B. Although the first-order natural frequencies of the two stable configurations are closed, one-way hopping is not well realized.

3.2 Dynamic analysis of a cantilevered asymmetric bi-stable composite laminates

Dynamic analysis of a cantilevered asymmetric bi-stable composite laminate with an initial configuration of stable state A is investigated. The external excitation frequency is equal to the first-order natural frequency of the system, 13.115Hz, and the excitation amplitude increases from 1mm to 7 mm. Select five groups of simulated data and sort them out as shown in the Fig. 10.

When the amplitude is 1mm, the obvious resonance is observed with the excitation of the first order natural frequency. After the transition period of the first eight seconds, it enters the steady-state response. It can be seen from phase trajectory that the steady-state response of bistable laminate is periodic vibration. When the amplitude is small, the nonlinear characteristics of bistable laminates are weak. When the amplitude is 3mm, the amplitude of the dynamic response significantly augments. After 0.45 seconds, it occurs chaotic vibration. Immediately, the amplitude reaches the critical value, resulting in a snap-through. When the amplitude is 5mm, the chaotic vibration of the structure begins after 0.3 seconds, and three times two-way snap-through occurs and then nonlinear vibration occurs near State A. When the amplitude is 7mm, the time of quasi periodic vibration is shortened to 0.2s. After that, the system makes four times two-way snap-through. After the snap-through, the plate vibrates non-linearly near stable state A. The critical amplitude of this configuration is 2.3mm. The snap-through occurs 0.5s after the start of the movement, accompanied by chaotic vibration.

When the initial configuration is stable state B, the configuration shows instability. Due to the principle curvature of Stable state B being along the transverse direction, the boundary condition of the cantilever greatly affects the configuration of the stable state. Under this circumstance, just a slight disturbance could lead the system to be out of equilibrium.

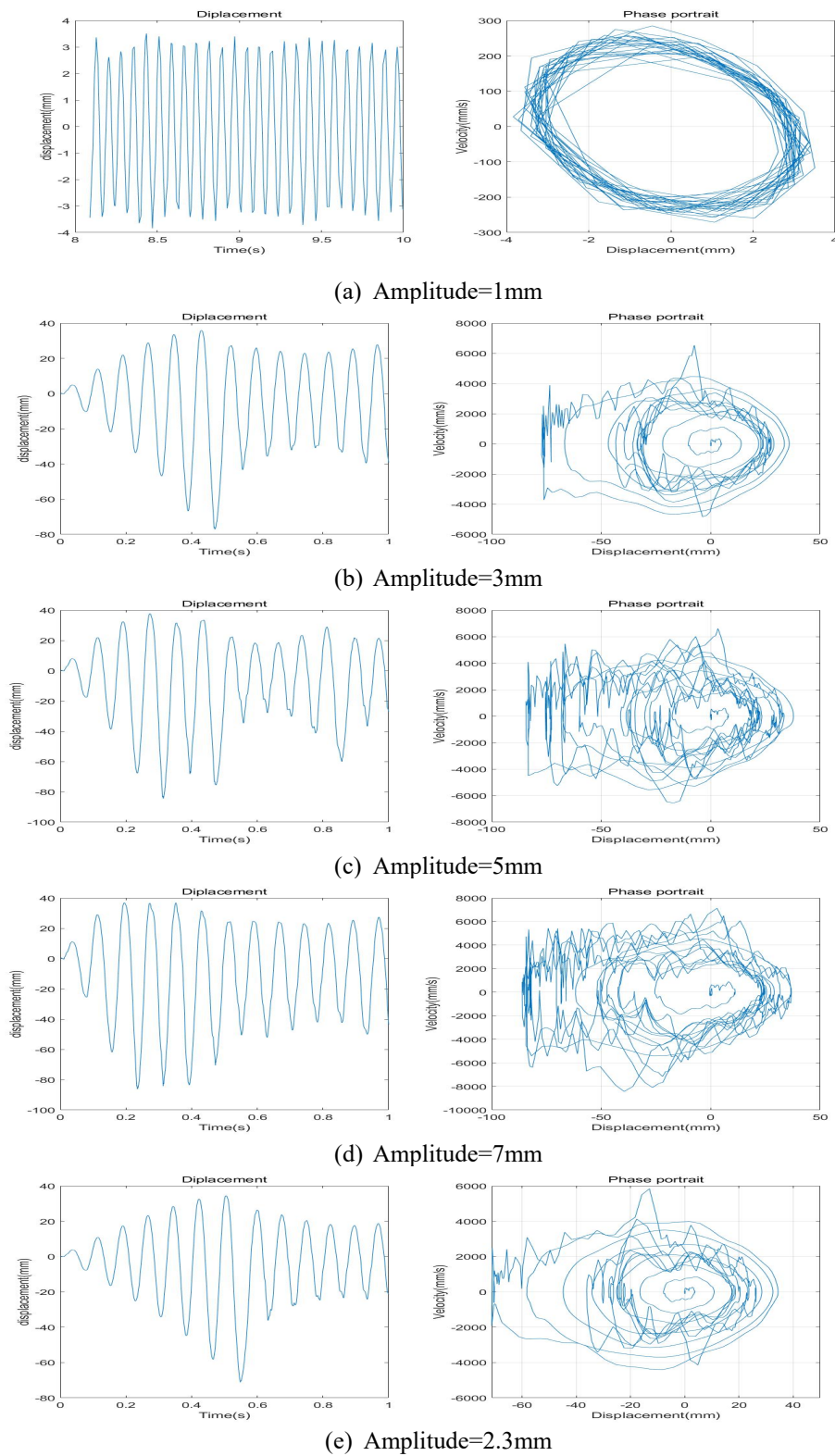

Figure 10 The displacement and the phase portrait of the cantilevered asymmetric bi-stable composite laminates from stable state B to stable state

4 CONCLUSIONS

- Through the dynamic response of asymmetric bi-stable composite laminated plate, the feasibility of resonance actuation under two boundary conditions is compared. In order to better realize the control ability of the snap-through process, it is necessary to increase the difference between the first-order natural frequencies of the two stable configurations. It can reduce chaotic oscillation caused by the continuous transitions of stable configurations.
- The non-linear characteristics of the asymmetric bi-stable composite laminate which is clamped at the center and free at four edges are stronger than that of a cantilevered laminate. However, the snap-through of the cantilevered laminate is more likely to induce.
- According to different modal frequencies, resonance actuation reduces the stiffness of the structure, thus significantly increasing the occurrence of snap-through. Combining this morphing strategy with the application of asymmetric bi-stable composite laminate provides a great possibility for future applications.

ACKNOWLEDGEMENTS

This work is supported by the Research Fund of State Key Laboratory of Mechanics and Control of Mechanical Structures(Nanjing University of Aeronautics and astronautics)(Grant No. MCMS-E-0522G02) and the National Natural Science Foundation of China (Grant No. 12102017).

REFERENCES

- [1] Hyer M W. Some observations on the cured shape of thin unsymmetric laminates[J]. *Journal of Composite Materials*, 1981, 15(2): 175-194.
- [2] Mattioni F, Weaver P M, Potter K D, et al. The application of thermally induced multistable composites to morphing aircraft structures[C]//*Industrial and Commercial Applications of Smart Structures Technologies 2008*. SPIE, 2008, 6930: 310-320.
- [3] Cottone F, Vocca H, Gammaitoni L. Nonlinear energy harvesting[J]. *Physical review letters*, 2009, 102(8): 080601.
- [4] Crawley E F, De Luis J. Use of piezoelectric actuators as elements of intelligent structures[J]. *AIAA journal*, 1987, 25(10): 1373-1385.
- [5] Dano M L, Hyer M W. Thermally-induced deformation behavior of unsymmetric laminates[J]. *International journal of solids and structures*, 1998, 35(17): 2101-2120.
- [6] Dano M L, Hyer M W. SMA-induced snap-through of unsymmetric fiber-reinforced composite laminates[J]. *International Journal of solids and Structures*, 2003, 40(22): 5949-5972.
- [7] Schultz M R, Hyer M W, Williams R B, et al. Snap-through of unsymmetric laminates using piezocomposite actuators[J]. *Composites science and technology*, 2006, 66(14): 2442-2448.
- [8] Bowen C R, Butler R, Jervis R, et al. Morphing and shape control using unsymmetrical composites[J]. *Journal of Intelligent Material Systems and Structures*, 2007, 18(1): 89-98.
- [9] Dano M L, Hyer M W. SMA-induced snap-through of unsymmetric fiber-reinforced

- composite laminates[J]. *International Journal of Solids and Structures*, 2003, 40(22): 5949-5972.
- [10] Schultz M R, Hyer M W, Williams R B, et al. Snap-through of unsymmetric laminates using piezocomposite actuators[J]. *Composites Science and Technology*, 2006, 66(14): 2442-2448.
- [11] Arrieta A F, Neild S A, Wagg D J. Nonlinear dynamic response and modeling of a bi-stable composite plate for applications to adaptive structures[J]. *Nonlinear Dynamics*, 2009, 58(1): 259-272.
- [12] Carrella A, Mattioni F, Diaz A A, et al. Static and dynamic analysis of a bistable plate for application in morphing structures[C]//7th European Conference on Structural Dynamics, Southampton. 2008: 7-9.
- [13] Senba A, Ikeda T, Ueda T. A two-way morphing actuation of bi-stable composites with piezoelectric fibers[C]//51st AIAA/ASME/ASCE/AHS/ASC Structures, Structural Dynamics, and Materials Conference 18th AIAA/ASME/AHS Adaptive Structures Conference 12th. 2010: 2744.
- [14] Arrieta A F, Bilgen O, Friswell M I, et al. Dynamic control for morphing of bi-stable composites[J]. *Journal of Intelligent Material Systems and Structures*, 2013, 24(3): 266-273.
- [15] Zhang W, Liu Y Z, Wu M Q. Theory and experiment of nonlinear vibrations and dynamic snap-through phenomena for bi-stable asymmetric laminated composite square panels under foundation excitation[J]. *Composite Structures*, 2019, 225: 111140.